

**AGENDA**  
**Codington County Board of Commissioners**  
**Codington County Court House, 14 1<sup>st</sup> Ave SE, Watertown SD**  
**Commission Chambers, Room #114**  
**9:00 a.m., Tuesday, March 11, 2025**

1. Pledge of Allegiance
2. Call for public comment. Public comment may be submitted in person or via telephone at 605-882-6248 or 605-882-6297
3. Conflict of interest items
4. Action to approve the March 11, 2025, agenda
5. Action to approve the March 4, 2025, minutes of the Board of Codington County Commissioners
6. Update on Jail Project by Tegra and Architecture Incorporated
7. Monthly Reports
  - a. 4-H Educator
  - b. Director of Equalization
  - c. Community Service Director
  - d. Auditor
8. Action to approve computer purchase for State's Attorney Office
9. Discussion/possible action to approve purchase of Belly Dump trailer for Highway Dept.
10. Action to authorize Chair and Auditor to sign the audit letter of engagement
11. Action to approve the Auditor's Acct. w/Treasurer and note monthly Register of Deeds fees
12. Action to approve abatement applications
13. Action to approve claims for payment
14. Action to approve personnel changes
15. Action to approve travel requests
16. Public Notices – a possible quorum of Commissioners could be in attendance at:
  - a. Weed/Towns & Townships Annual meeting, March 13<sup>th</sup>, 2025, 6:00 p.m., Extension Center Complex
17. Old Business
18. New Business
19. Open
  - a. Public Comments
  - b. Commission Comments
20. Action to enter into Executive session per SDCL 1-25-2
  - (1) Discussion of personnel issues
  - (2) Consulting with legal counsel or reviewing communications from legal counsel regarding proposed or pending litigation or contractual matters
  - (3) Preparing for contract negotiations with employees or employee's representatives
  - (4) Discussing information listed in SDCL 1-27-1.5 (8) and 1-27-1.5 (17) (safety or disaster)

**21. Action to adjourn upon completion of agenda items**

**Codington County does not discriminate on the basis of race, color, national origin, sex, religion, age, or disability in employment or the provision of service.**

**Official Proceedings  
County of Codington  
Codington County Court House  
14 1<sup>st</sup> Ave SE  
Watertown, SD 57201**

March 04, 2025

The Codington County Commissioners met in regular session at 9:00 a.m., Tuesday, March 04, 2025, at the Codington County Court House. Commission members present were: Lee Gabel, Tyler McElhany, Myron Johnson, Troy VanDusen and Randall Schweer; Chair VanDusen, presiding. The pledge of allegiance was led by Facility Manager, Steve Molengraaf.

**CALLS FOR PUBLIC COMMENT AND CONFLICT OF INTEREST ITEMS**

Chair VanDusen called for public comments to be taken up during the open portion of the meeting; none were offered. There were no conflict-of-interest items to note.

**PERSONAL PRIVILEGE**

Chair VanDusen extended condolences to Mayor Ried Holien and the rest of the Holien family for the passing of Carole Stein Holien.

**AGENDA APPROVED**

Motion by Gabel, second by Schweer, to approve the agenda for March 04, 2025, as posted; all voted aye; motion carried.

**MINUTES APPROVED**

Motion by McElhany, second by Johnson, to approve the minutes of February 25, 2025; all voted aye; motion carried.

**REQUEST TO SELL ALCOHOL AT EXTENSION COMPLEX /BOYS & GIRLS CLUB EVENT**

Kelly Jaderborg, Director of Resource Development, with the Watertown Boys and Girls Club, met with the Board to request authorization to sell alcohol during the Blue Door Derby Camel Races event, scheduled for April 25<sup>th</sup>, 2025 at the Codington County Extension Center Complex. A liquor license will be transferred from Dempsey's for this event. Motion by McElhany, second by Schweer, to approve this request; all voted aye; motion carried.

**SD DEPT. OF LEGISLATIVE OPENING AUDIT CONFERENCE**

Kasie Ingraham and Natalie Zirbel, SD Dept. of Legislative Audit, met with the Board to review procedures that will be used during Codington County's regularly scheduled biennial audit for the years 2023 & 2024. Ms. Ingraham informed the Board the cost for this audit is \$94.00 per hour.

**MONTHLY REPORTS**

**Veterans Service Officer, Todd Rose**, updated the Board: metrics for the month, 181 open claims (working claims) 74 pending action from VA, 67 completed (YTD), Hamlin 10 open (working claims) 6 pending from VA, 2 completed (YTD), currently working for 13 veterans and have completed 3 claims for veterans from outside our county; \$20,999 for the month Feb. 2025, increase in monthly compensation for veterans or their dependents YTD monthly increase \$31,098; \$183,356 for the month of February retro-payment to bring a claim current to monthly compensation YTD retro-payments \$284,797; 2 veteran DAV transports in February, 3 - currently scheduled for March, 8 drivers; been busy in the office, received contacts from Farm Show with the VA Public Contact Office having a booth there, they provided the VA Office phone number to local veterans to contact about possible benefits they may be

Codington County, 04 March 2025

eligible for; will meet with Commanders of the Veteran Organizations, will be on the radio Thursday morning; will be attending the Hamlin County Commission meeting March 18<sup>th</sup>, 2025, will be reviewing last year's numbers and review the contract/budget for 2025; Memorial Day Ceremony will be handled by the Watertown American Legion, more details to come in next months; Veterans Information Event to be held at the Watertown Readiness Center on July 19<sup>th</sup>, 2025 from 10:00 a.m. to 2:00 p.m., are in the planning phase, there will be representatives from VA and other organizations that will have informational booths.

**COMMUNITY SERVICE OFFICE MOU WITH SOUTH DAKOTA COORDINATED ENTRY SYSTEM**

Motion by Johnson, second by McElhany, to authorize Chair to sign updated 2025 MOU between Codington County Community Service Office and South Dakota Housing for the Homeless Consortium; all voted aye; motion carried

**COMMUNITY SERVICES OFFICE CLOSURE**

Motion by McElhany, second by Schweer, to approve the Community Service Office to be closed Wednesday, March 5<sup>th</sup>, 2025 and Thursday, March 6<sup>th</sup>, 2025, for staff to attend Transition to Success training conducted by Sioux Falls Helpline Center; all voted aye; motion carried.

**CLAIMS**

Motion by McElhany, second by Gabel, to approve the following claim for payment: Watertown Public Opinion \$1,061.21; all voted aye; motion carried.

**PERSONNEL CHANGE**

Motion by Gabel, second by McElhany, to approve the following personnel change: Angie Collignon, Substance Use and Justice Programs Coordinator, at the Community Service Office, full-time effective 4/01/2025, Grade 40/Step 10, \$6225.72/month or \$74,708.64/year; Bonnie Molengraaf, Accountant Administrator, Auditor's Office, full-time effective March 01, 2025, Grade 35/Step 1, \$25.80/hour; all voted aye, motion carried.

**TRAVEL REQUEST**

Motion by Gabel, second by Johnson, to approve the following travel requests: State's Attorney Office employees to attend a conference and training; all voted aye; motion carried

**OPEN**

**Commission comments-** Commissioner Gabel mentioned there is another Jail Project meeting this week.

**ADJOURNMENT**

Upon conclusion of all business to come before the Board, a motion was made by Johnson, second by Schweer, to adjourn at 9:22 a.m., all voted aye; motion carried.

ATTEST:

---

Brenda Hanten  
Codington County Auditor

Codington County does not discriminate on the basis of color, national origin, sex, religion, age, or disability in employment or the provision of service.  
Published once at the total approximate cost of \$\_\_\_\_\_

Solution Proposal

60965



**CONNECTING POINT**  
A Twotrees Company



60965 .01

504 Jenson Ave SE Watertown, SD 57201 P: 605.882.1555  
 3710 S Kiwanis Ave. Sioux Falls, SD 57105 P: 605.361.8881  
 1680 East Capitol Ave Suite B Bismarck, ND 58501 P: 701.258.6689  
 114 Main St. N Ste. 202F Hutchinson, MN 55350 P: 320.582.0234  
 801 S 42nd Street, Suite G1 Grand Forks 58201

**Codington County States Attorney - Alison Replacement PC**

March 3, 2025

**Bill To:**  
Codington County States Attorney  
Alison Bakken  
14 1st Ave SE  
Watertown, SD 57201

**Phone:**  
(605) 882-6276

**Ship To:**  
Codington County States Attorney  
Alison Bakken  
14 1st Ave SE  
Watertown, SD 57201

Email: abakken@codington.org

Salesperson: Greg Richter

	Description	Price Each	Qty	Ext Price
<b>Items</b>				<b>\$2,297.45</b>
1	<p><b>HP Elite 800 G9 SFF</b></p> <p>HP Elite 800 G9 Desktop Computer - Intel Core i5 14th Gen i5-14500 - vPro Technology - 16 GB - 512 GB SSD - Small Form Factor - Black Intel Q670 Chip - Windows 11 Pro - Intel UHD Graphics 770 DDR5 SDRAM - English Keyboard - 260 W</p> <p><i>Pricing Expires 3/31/25</i></p>	\$1,290.00	1	\$1,290.00 ✕
2	<p><b>HP E24 G5 23.8" Full HD Mntr</b></p> <p>HP E24 G5 23.8" Full HD Edge LED LCD Monitor - 16:9 - 24" Class - In-plane Switching (IPS) Technology - 1920 x 1080 - 250 Nit - 5 ms - 75 Hz Refresh Rate - HDMI - DisplayPort - USB Hub</p> <p><i>3 24" monitor solution Pricing Expires 3/31/25</i></p>	\$195.55	3	\$586.65 ☐ <i>Option Item -Not Included in Total</i>
3	<p><b>HP E27 G5 27" HD LCD Monitor</b></p> <p>HP E27 G5 27" Full HD LCD Monitor - 16:9 - Black, Silver - 27" Class - In-plane Switching (IPS) Technology - 1920 x 1080 - 16.7 Million Colors - 300 Nit - 5 ms - 75 Hz Refresh Rate - HDMI - DisplayPort - USB Hub</p> <p><i>2 27" monitor solution Pricing Expires 3/31/25</i></p>	\$210.40	2	\$420.80 ☐ <i>Option Item -Not Included in Total</i>
4	<p><b>Monthly Connect Care MSP</b></p> <p>Recurring monthly fee for Premium Connect Care, Standard three year agreement. Includes 24x7x365 Remote Monitoring, Monthly Reports, Automated Operating System Patch Management, Antivirus and/or Antispam Monitoring, Updates and Remediation (License Required) Automated Disk Optimization, Desktop and Server Labor for covered equipment both Remote and Onsite (mileage within 75 miles of nearest Connecting Point location is included), Annual Network Documentation and Network Security Scan, Yearly Review and Planning, Remote Checkups</p> <p><i>1 replacement PC = \$0.00</i></p>	\$0.00	1	\$0.00 ✕
5	<p><b>Onsite setup of PC</b></p> <p>Unbox and run initial setup of HP Elite 800 SFF - user is Alison Bakken., this includes the installing of the latest Microsoft updates, installation of Codington Trend Micro antivirus. Installation of Alliscons MS365 Business Standard licensing. On site setup at customer site connecting to the customer's existing Domain network and the moving user profile data off existing HP PC if applicable. Install New Case Management software.. Also includes installing of printer drivers for existing local and network printers and running test prints. Clean up work area, dispose of boxes, confirm with customer that the work area is acceptable following the replacement of PC(s).</p> <p>If client has MSP contract, please record SN of unit being replaced in labor notes. Also be sure to check that the Kaseya agent and Trend antivirus have been updated for new unit and removed from the unit being replaced if applicable.</p> <p><i>Covered under Codington Connect Care MSP a \$395.00 value</i></p>	\$0.00	1	\$0.00 ✕

	Description	Price Each	Qty	Ext Price
6	<b>Onboarding of MSP device</b> 1 replacement PC Implementation of Connect Care monitoring agents on equipment to be covered. Register and verify equipment is live and available to monitor and manage. Provide a master list of equipment to be covered to DISPATCH for update of CRM. See scope detail for items to be completed for Kaseya onboarding.  * Check the AD server computers list, Kaseya agent portal and Trend Micro antivirus console have been populated with the new equipment info and removed any computer equipment being retired from these same consoles / portals, document this in work order.  Be sure to check that the Kaseya agent and Trend antivirus have been updated for new unit and removed from the unit being replaced if applicable.  1 replacement PC	\$0.00	1	\$0.00 ☒

**Payment Terms:**

Payment terms are established at the time of the order. We accept cash or check along with credit card, but our company policy is to limit credit card payment acceptance to \$4,000.00 or less per account per month. We also offer leasing and other options to manage your purchase. Account setup time can take 1-2 business days to review and approve.

**Subtotal** \$1,290.00

**Tax** \$0.00

**Return Policy:**

Unopened items can be returned 15 days from date of delivery without restock fees. Items that have been opened will have a 15% restock fee and can be returned up to 30 days from date of purchase. There are no returns for SPECIAL ORDER, CUSTOM CONFIGURATIONS or items that are older than 30 days from date of purchase.

**Total** \$1,290.00

**Shipping Disclaimer:**

Connecting Point is not responsible for any damages that occur during shipping. As the recipient, you are responsible for reporting damaged shipments and to inspect all boxes prior to signing for deliveries. You also have an option of refusing the shipment of any damaged goods. If not refused, take pictures of any damage and have the delivery driver sign off on shipping documentation. Any damage done from shipping must be brought to our attention immediately at time of receiving the product. Delayed reporting of any damages or missing parts may result in rejection of your claim. Hold all damaged goods and all original packing materials for inspection. Shipping insurance is available at an additional cost.

Quoted by: \_\_\_\_\_

Accepted by: \_\_\_\_\_



February 27, 2025

CODINGTON COUNTY  
HIGHWAY DEPARTMENT  
1201 10TH ST NW  
WATERTOWN, South Dakota 57201-1053

Dear Lynn,

We are pleased to quote the following for your consideration.

Trailing Model: TKBD22-43 Trailer

**STOCK NUMBER: NEW ORDER****MACHINE SPECIFICATIONS**

TKBD22-43 ADVANTAGE SERIES	\$63,163.00	TRI AXLE: 23k AIR RIDE w/ PRESSURE GAUGE	\$8,858.00
BOTTOM DUMP TRAILER 38' 11"	\$0.00	49" / 50" SPACING	\$0.00
9'3" OVERALL HEIGHT, 102" WIDTH	\$0.00	STANDARD AXLE	\$0.00
42'8" OVERALL LENGTH	\$0.00	20K DRUM BRAKES-6" AUTOSLACKS	\$0.00
11 6" GATE; 22 CU YD CAPACITY	\$0.00	2S1M/2S2M ANTI-LOCK BRAKE SYSTEM	\$0.00
48" 5TH-WHEEL HEIGHT	\$0.00	STEEL HUB- CAST DRUM (PER AXLE)	\$0.00
STANDARD DUTY GATE	\$0.00	8.25 X 22.5 10-HOLE STEEL	\$0.00
FRONT & REAR STRIKER PLATES AND	\$0.00	STANDARD WHEEL = 8.25 X 22.5	\$0.00
ADJUSTABLE GATE STOPS	\$0.00	CONTINENTAL 11R22.5 ECO+HT3 14PL	\$0.00
STEEL CYLINDERS	\$0.00	STD TIRE CONTINENTAL 11R22.5 ECO	\$0.00
SELF CLOSING VALVE W VARI CONT	\$0.00	LED LIGHTS	\$0.00
WIRED REMOTE (2)	\$104.00	NO TARP	\$0.00
60 GALLON RESERVOIR	\$0.00	STD MUDFLAPS W/ ANTI SAIL BRACKT	\$0.00
HD PUSH BLOCK	\$0.00	GATE MOUNTED PIN-STYLE	\$0.00
STD WINDOW DEFLECTOR (1ST AXLE	\$0.00	DOCUMENT HOLDER 4-1/2"ROUND	\$0.00
STD HOPPER LOCATION FOR 4 AXLE	\$0.00	S7230 GREY METALLIC W/ BLACK DECALS	\$0.00
LOWER HOPPER SHEET .120 GRADE 80	\$0.00	REAR WIRED REMOTE	\$349.00
STANDARD DUTY CROSSMEMBER	\$0.00	8" WOOD EXTENSIONS (3 CUBIC YDS)	\$695.00
		1/4" HMW POLY LINER ON FRONT AND REAR HOPPER SLOPES	\$1353.00

LIST PRICE	\$74,522.00
SOURCEWELL 15% DISCOUNT PER CONTRACT #092922-TKI	\$11,178.30
PDE, DOT INSPECTION, AND FACTORY FREIGHT	\$2,204.44
SOUCEWELL SALE PRICE	\$65,548.14

**WARRANTY**

Standard Warranty:

12 Months Standard Warranty excluding mileage

We believe the equipment as quoted will exceed your expectations. Thank you for the opportunity to quote this equipment.

Toby Royer  
Machine Sales Representative  
TobyRoyer@butlermachinery.com  
605-261-2881



<< Search Results

**BUY  
WHAT  
YOU  
WANT** WITH [Check Buying Power](#)



Photos (9)



This website uses cookies to collect data and enable essential site functionality, marketing, personalization, and analytics. [View our Cookies Policy and Privacy Policy to learn more.](#) ⓧ





**42' TC3000  
Bottom Dump**

ORDER  
 QUOTE # MIDL00145

Weight 15,450 lbs  
Capacity 20 cu yds

DATE: February 13, 2025  
 DEALER: Peterson Motors Co.  
 END USER: \_\_\_\_\_  
 SERIAL NO: \_\_\_\_\_

CONTACT: \_\_\_\_\_  
 CUSTOMER PO: \_\_\_\_\_

**STANDARD SPECIFICATIONS**

- Oscillating Upper Fifth
- High Tensile Sides
- Composite Bushings (Greaseless)
- 8" Composite Air Cylinders
- Bolt-on Step Bumper
- S04 Valve
- 22,500 lb Axles 77" Track
- 11R22.5 Double Coin RR706
- Steel Unimount Wheels
- Auto Slacks
- Haldex ABS (2S1M)
- Internal Common Ground Harness
- 50% Conspicuity Tape
- Accent Striping (Double 1" Tape)
- LED Lighting

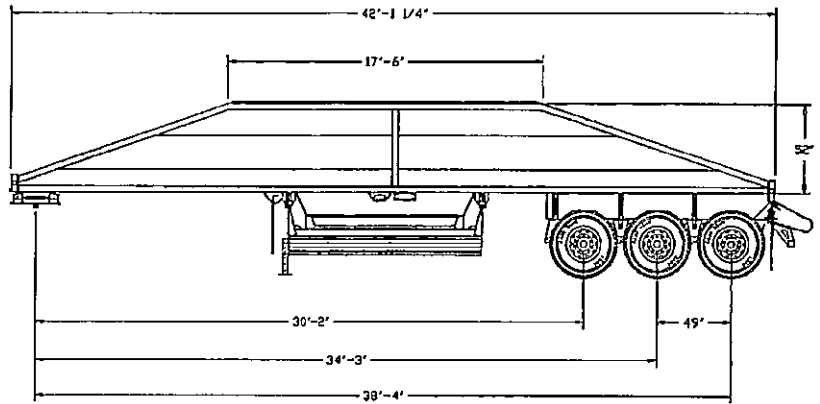

**SIDE HEIGHT**

52"  
 58" (add 2 cu yds.)

**LANDING GEAR**

Post Type  
 Two Speed (may interfere with tractor frame ends)

**BOARDS**

No Boards  
 Self Shedding Angle  
 2" x 10" Boards with 9" Brackets (add 4 cu yds.)  
 Brackets Only  
 7"  
 9"

**SUSPENSION (Ride Height 17")**

Ridewell 260

**OPTIONS**

Bolt-on Push Block c/w Under-Run Bumper  
 Shed Plate Track Only  
 Shed Plate with Tracking (Plywood)  
 Plywood Lined Sides  
 Axle Guards  
 1st Axle Only  
 All Axles  
 Mac Valve  
 Mac Valve/EGS System c/w In Cab Control  
 Versa Valve  
 Versa Valve c/w In Cab Control  
 Haldex ABS (4S2M)  
 Haldex ABS (6S3M) (all axles)  
 100% Conspicuity Tape  
 Open/Close Controller on Separate Curly Cable

**LIFT AXLE**

Manual Electric Lift Axle  
 Midland Auto Lift / Lift Axle  
 1 Lift (1st axle)  
 1 Lift (3rd axle)  
 2 Lifts (1st & 2nd axles)  
 2 Lifts (1st & 3rd axles)

Note: Weights, capacity and dump angle are calculated and may vary. Selected trailer components subject to availability.

\*\*Quotation subject to review / revision after 30 days\*\*

Updated Order Form  
February 10, 2025

**42' TC3000 Bottom Dump**

**HUB, DRUM & AXLE CONFIGURATION**

Unimount (Long Stud)

**TIRES AND RIMS**

No Tires/Rims  22.5  24.5

**Tires**

Double Coin RR706

**Rims**

Unimount White (Steel) (12)

Accuride Alum Machined (6)

Accuride Alum Polished (6)

Alum Semi Polish (6)

**TARPS**

No Tarp

Michel's Dura Flip

(Mesh, Aluminium Arms, Clutch Crank, Manual/Chain, Manual Lockdown)

Vinyl Tarp

Electric Direct Drive

Michel's Air Flip Tarp (Less Lockdown)

\*\*Manual Lockdown NOT installed with Air Flip Tarps\*\*

Vinyl Tarp

NOTE: Board Height: \_\_\_\_\_

Michel's Gravel Guard (Mesh, 12" Hoops, Belt Drive)

Vinyl Tarp

Manual Chain Drive

18" Hoops

Electric Chain Drive Kit

With Manual Belt Drive Back up

With Manual Chain Drive Back up

Deluxe Package

(Powder Coated Crank & Pulleys & Stainless Steel Cable)

**Tarp Color**

Black

Red

**PAINT**

*\*Specialty Colors and Tapes Subject to Extra Charge\**

**Body**

Black - CLR28948

Navy Grey - CLR34067

Red - CLR40215

Silver Metallic - CLR27054

Slate Grey - CLR27041

White - CLR28957

Yellow - CLR27047

**Striping (Double 1" Tape)**

*Will provide best color match available, cannot guarantee perfect match.*

Black - 02  Silver - 06

Red - 92  White - 08

**Decals**

Black  Silver

Red  White

**Boards**

Black  Slate Grey

Navy Grey  White

Red  Yellow

Silver Metallic

**FLAPS (see drawing on next page)**

Standard Package (Yellow on drawing)

Option Package #1 (Blue & Yellow on drawing)

*\*\*Includes Standard Package*

Option Package #2 (Pink, Blue, & Yellow on drawing)

*\*\*Includes Standard Package & Option Package #1*

**OTHER**

Poly lining front and rear slopes only

PRICE : \$70,200.00

Note: Weights, capacity and dump angle are calculated and may vary. Selected trailer components subject to availability.

\*\*Quotation subject to review / revision after 30 days\*\*

OFFICIAL STATEMENT OF FEES COLLECTED  
REGISTER OF DEEDS STATEMENT OF FEES COLLECTED DURING THE MONTH

OF FEBRUARY, 2025

The sum of **\$35,362.85** in fees has been collected by me as Register of Deeds for FEBRUARY, 2025

Ann Rasmussen being duly sworn, deposes and says that she is the Register of Deeds in and for CODINGTON COUNTY, State of South Dakota; that the foregoing statement is a true and correct report of all fees collected by me as such Register of Deeds, as required by law, during the month of FEBRUARY, 2025

Ann Rasmussen

Register of Deeds

Subscribed and sworn to before me this 3<sup>rd</sup> day of March 2025

Brenda Hanten

**CERTIFIED BIRTHS**

State Children's Fund (\$2.00)	\$ 202.00
County General Fund (\$5.00)	\$ 505.00
State EVRSS Fund (\$5.00)	\$ 505.00
State General Fund (\$3.00)	\$ 303.00
<b>TOTAL</b>	<b>\$ 1,515.00</b>

**CERTIFIED DEATHS**

County General Fund (\$5.00)	\$ 895.00
State General Fund (\$4.00)	\$ 716.00
State EVRSS Fund (\$6.00)	\$ 1,074.00
<b>TOTAL</b>	<b>\$ 2,685.00</b>

**Receipt Totals**

By Date: 2/3/2025 12:00:00 AM - 2/28/2025 11:59:59 PM; Departments: All; Cash based.

**Summary:**

**Codrington County**

Monday, March 3, 2025 2:03 PM

**Receipt Item Totals**

	Paid	Charged	Debited	Total
Document:	\$28,608.00	\$652.00	\$0.00	\$29,260.00
Non Document:	\$4,618.50	\$1,217.30	\$0.00	\$5,835.80
<b>Subtotal:</b>	<b>\$33,226.50</b>	<b>\$1,869.30</b>	<b>\$0.00</b>	<b>\$35,095.80</b>

**Payment on Account Totals**

Applied:	\$2,136.35
Refunded:	\$0.00
Unposted:	\$0.00
<b>Net Posted:</b>	<b>\$2,136.35</b>

**Payments & Refunds**

ACH:	\$22,197.50
Cash:	\$1,949.50
Check:	\$11,200.85
Money Order:	\$15.00
<b>Total:</b>	<b>\$35,362.85</b>

**Revenue Account Activity**

	Total Received	Paid on Receipt	Applied from POA	Adjusted
101-0-321.00 Marriage License 1	\$70.00	\$70.00	\$0.00	\$0.00
101-0-341.21 Reg. Deeds Filing/Recording 2	\$5,680.00	\$5,095.00	\$585.00	\$0.00
101-0-341.22 Reg. Deeds Transfer fees 3	\$22,498.00	\$22,498.00	\$0.00	\$0.00
229-0-321.00 Domestic Abuse Marriage Lic. 6	\$210.00	\$210.00	\$0.00	\$0.00
726-0-209.00 Reg. Deeds Fees - State 8	\$2,800.00	\$2,350.00	\$450.00	\$0.00
101-0-341.29 Reg. Deeds Other Fees 4	\$3,004.85	\$2,008.50	\$996.35	\$0.00
250-0-341.21 M&P Relief ROD Filing/Rec 7	\$660.00	\$597.00	\$63.00	\$0.00
769-0-209.00 M&P Relief ROD Allocation 9	\$440.00	\$398.00	\$42.00	\$0.00
<b>Total:</b>	<b>\$35,362.85</b>	<b>\$33,226.50</b>	<b>\$2,136.35</b>	<b>\$0.00</b>

FILED

MAR 03 2025

CODRINGTON COUNTY AUDITOR

Document Pro



## AUDITOR'S ACCOUNT WITH THE COUNTY TREASURER

To the Honorable Board of County Commissioners, Codington County:

I hereby submit the following report of my examination of the cash and cash items in the hands of the County Treasurer of the County of Codington as of the last business day in February 2025.

Cash on Hand	\$8,350.39
Checks in Treasurer' possession	\$74,454.35
less than 3 days	\$0.00
Credit Card Charges	\$12,876.41
Cash Items	\$325.00
<b>TOTAL CASH ASSETS ON HAND</b>	<b>\$96,006.15</b>

RECONCILED CHECKING	
Reliabank (Memorial Park)	\$33,316.25
Reliabank Dakota	\$25,543,550.61
INVESTMENTS	
SD Public Funds Investment	\$1,070.45
Plains Commerce Bank CD's	\$2,526,556.85

<b>TOTAL CASH ASSETS</b>	<b>\$28,200,500.31</b>
--------------------------	------------------------

**GENERAL LEDGER CASH BALANCES:**

General	\$9,072,730.65
General restricted cash	\$500,000.00
Sp. Revenue	\$9,855,581.41
County Jail Billed	\$7,012,312.99
Sp. Revenue restricted cash	\$0.00
Custodial	\$1,759,875.26
Schools	\$ 924,617.25
Townships	\$ 78,234.21
City/Towns	\$ 181,088.03

<b>TOTAL GENERAL LEDGER CASH</b>	<b>\$28,200,500.31</b>
----------------------------------	------------------------

Dated this 3rd day of March 2025

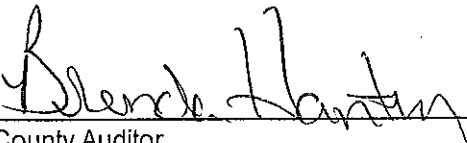
  
\_\_\_\_\_  
County Auditor

**AUDITOR'S MONTHLY SETTLEMENT WITH TREASURER  
CODINGTON COUNTY  
DATE: March 3, 2025**

**CASH ON HAND IN TREASURER'S OFFICE**

Silver and Pennies.....	\$91.39
Ones.....	\$229.00
Fives.....	\$380.00
Tens.....	\$470.00
Twenties.....	\$2,480.00
Fifties.....	\$1,100.00
Hundreds.....	\$3,600.00
Cash Items.....	\$325.00
Credit Card Charges.....	\$12,876.41
Checks.....	\$74,454.35
<b>TOTAL CASH ON HAND</b>	<b>\$96,006.15</b>

**CHECKING ACCOUNT BALANCE:**

<u>Reliabank (Memorial Park)</u>	\$33,316.25
<u>Reliabank Dakota</u>	\$25,543,550.61

**INVESTMENTS:**

<u>SD Public Funds Investment Trust</u>	\$1,070.45
<u>Plains Commerce Bank CD's</u>	\$2,526,556.85

**OTHER ACCOUNT BALANCES: \$28,104,494.16**

**GRAND TOTAL CASH AND BALANCES: \$28,200,500.31**

**GENERAL LEDGER CASH AND INVESTMENT BALANCES BY FUNDS:**

General Fund	\$9,072,730.65
General Fund restricted cash	\$500,000.00
Sp. Revenue Funds	\$9,855,581.41
County Jail Billed	\$7,012,312.99
Sp. Revenue Funds restricted cash	\$0.00
Custodial Funds	\$1,759,875.26

**TOTAL GENERAL LEDGER CASH \$28,200,500.31**